

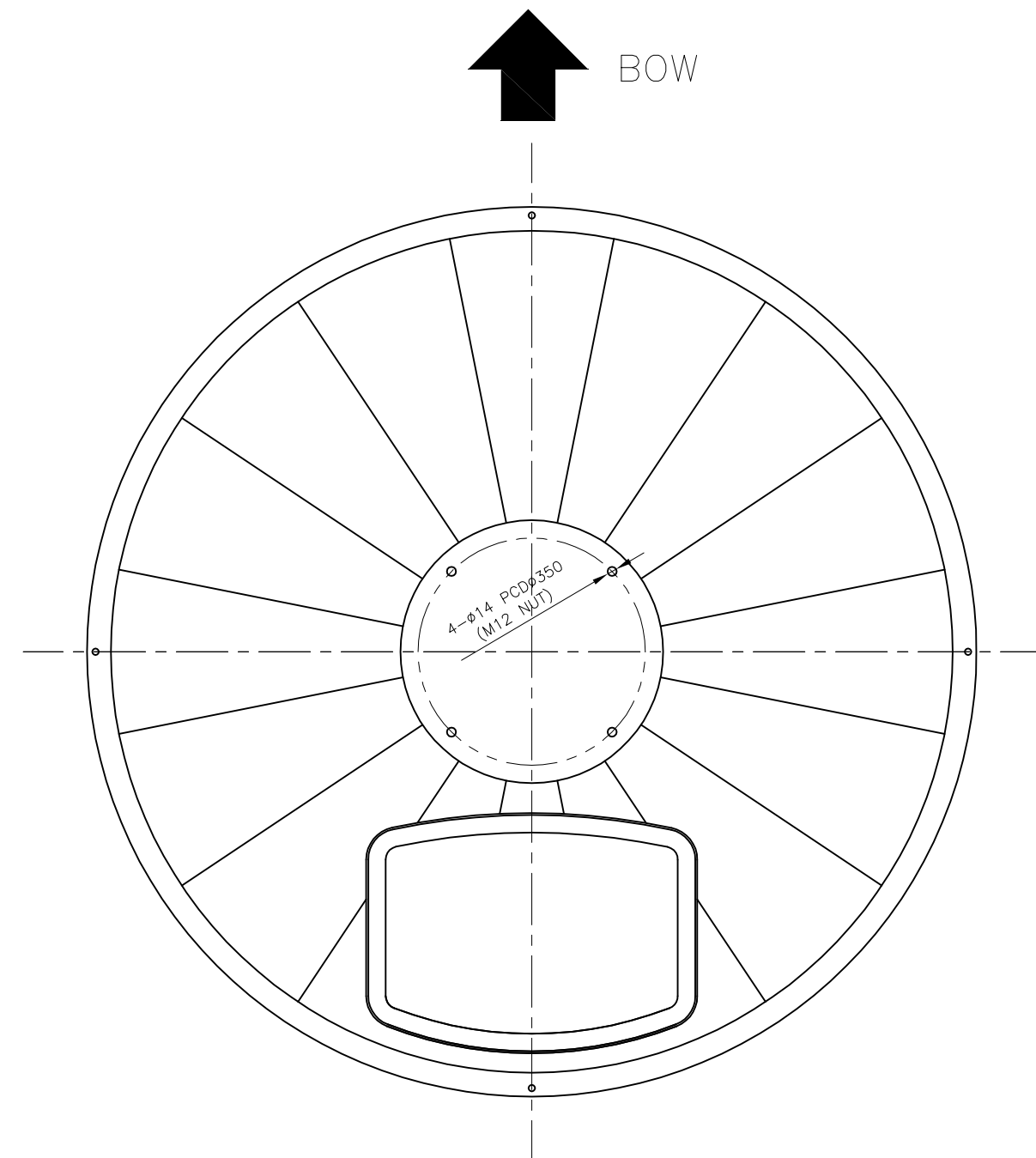

REVISION HISTORY			
REV	DESCRIPTION	DATE	BY

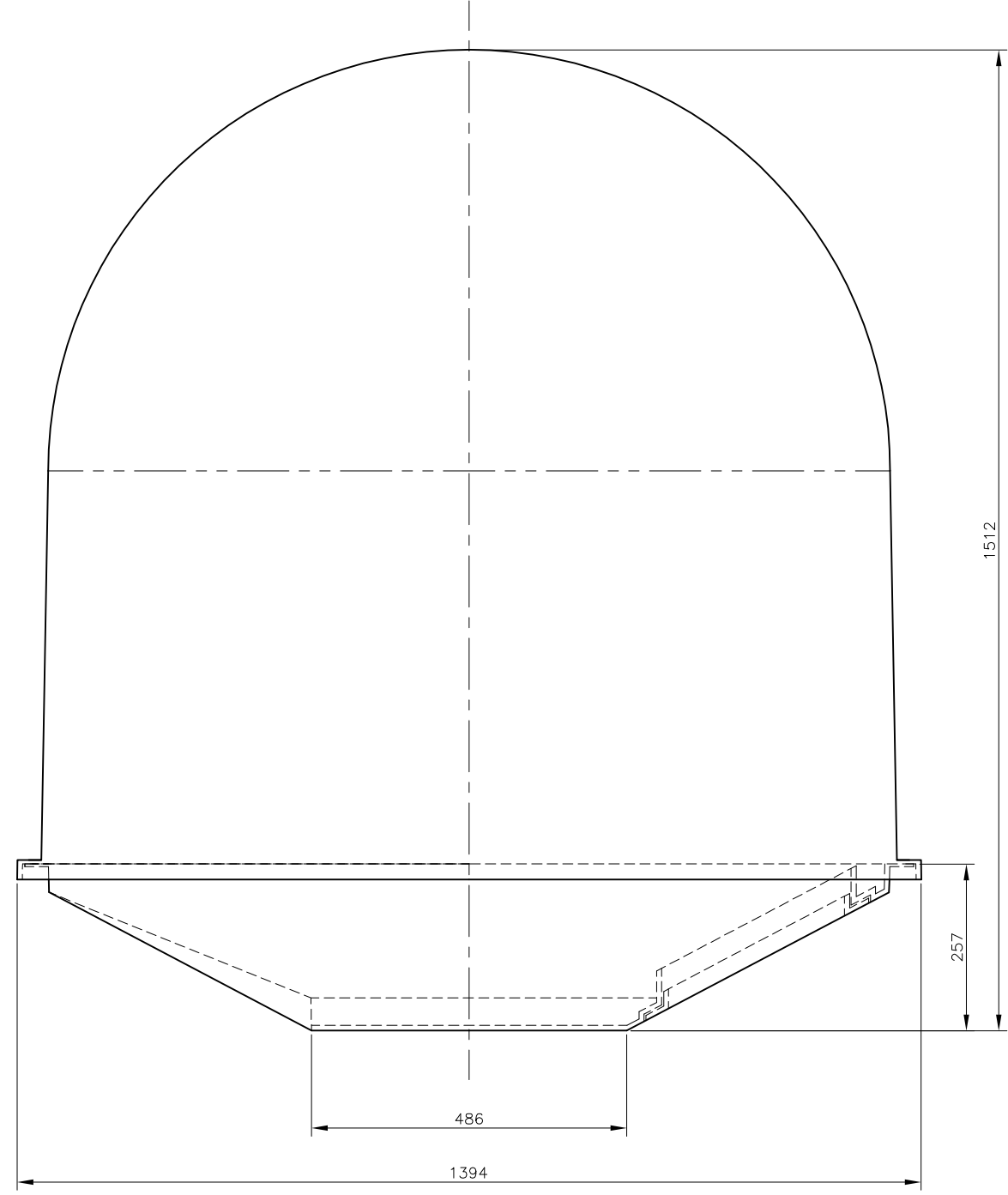

MOUNTING SURFACE PATTERN
(BOTTOM VIEW)

TOLERANCES UNLESS OTHERWISE SPECIFIED		MATERIAL	2009.10.22	QUANTITY	TITLE	
0.5 ~ 6	±0.1	-	⊕ ⊖	1EA	Radome_S10Z10MK2	
6 ~ 30	±0.2	FINISH	SCALE	WEIGHT	DWG NO.	SHEET
30 ~ 120	±0.3	-	1:10	—(kg)	KNS-	1/1
120 ~ 400	±0.5	DRAWN	CHECKED	APPROVED	 KNS, Inc.	
400 ~ 1000	±0.8	PHANJOONG				
1000 ~ 2000	±1.2					A3